

## 典型性能 Features

- ◆ 30-50 瓦功率输出 (30-50 Watts of Output Power)
- ◆ 超宽电压输入 (4:1 Wide Range Input)
- ◆ 长期短路保护, 自恢复 (Short Circuit Protection, Automatic Recovery)
- ◆ 小型化封装 (Small Package)



## 电气特性 Electrical Specifications

输入特性 Input	Min	Type	Max	Notes
输入电压范围	40V	110V	160V	40V
Input Voltage Range	9V	24V	36V	9V
启动延时时间 Start-up Delay Time		10mS		
控制功能		ON		CNT 悬空或接TTL高电平 CNT pin left open or CNT pin connected to TTL logic high
ON/OFF Control		OFF		CNT 与-Vin 相连 CNT pin is at a logic low
逻辑低 Logic Low			1.2 V	
输入欠压保护	30V		40V	110V输入
Input. Under-voltage Lockout	7V		9V	24V输入
输出特性 Output	Min	Type	Max	Notes
输出电压精度 Set point Accuracy		±1%	±3%	
负载效应 Load Regulation		±0.5%	±1%	
源效应 Line Regulation		±0.5%	±1%	
输出电压调节 TRIM Range			±10%	
动态响应 Dynamic Response			4%Vo Pk deviation 400μS settling time	50~75% load 50~25% load
温度系数 Temperature Regulation		±0.2%/°C		
输出过流保护 Current Limit Threshold	110%		160%	
输出过压保护 Over-voltage Protection	110%		140%	
过温度保护 Over Temperature Protection	105°C	115°C	125°C	
短路保护 Short-Circuit Protection	长期短路自恢复 Continuous, Automatic Recovery			
综合特性 General	Min	Type	Max	Notes
隔离电压	2000VAC			110V INPUT TO OUT
Isolation Voltage	1500VAC			24V INPUT TO OUT

开关频率 Switching Frequency		300KHz		
平均故障间隔时间 MTBF		2×10 <sup>6</sup> Hrs		Mil HDBK 217F Tc=25℃
工作壳温 Case Temperature	铁路级	-40℃		+95℃
储存温度 Storage Temperature		-55℃		+125℃
相对湿度 Relative Humidity		-55℃		+125℃
管脚焊接温度 Pin Solder Temperature		10%		90%
手工焊接时间 Hand Soldering Time			250℃	Wave Solder <10S
传导 Conducted Emission	GBT24338.4-2009/TBT 3034-2002 (推荐电路见图)			
静电放电 Electrostatic Discharge	GB17626/EN61000-4-2 Contact ±6KV air ±8KV perf. Criteria A			
浪涌抗扰度 Surge Immunity	GB17626/EN61000-4-5 ±2KV (推荐电路见图) perf. Criteria A			
脉冲群抗扰度 Electrical Fast Transient	GB17626/EN61000-4-4 ±2KV (推荐电路见图) perf. Criteria A			

型号 Models	输入电压范围 Input Voltage Range	输出电压 (Vdc) Output Voltage	输出电流 (A) Output current	纹波噪声(mv) Ripple and noise	典型效率 Efficiency	容性负载 (μF) Max.Capacitor Load
WRSD30-110S3V3	40-160V	3.3	6	50	86%	6800
WRSD30-110S5	40-160V	5.05	6	50	90%	6800
WRSD30-110S12	40-160V	12	2.5	100	90%	680
WRSD30-110S15	40-160V	15	2	100	90%	680
WRSD30-110S24	40-160V	24	1.25	100	89%	470
WRSD50-110S3V3	40-160V	3.3	10	50	86%	6800
WRSD50-110S5	40-160V	5.05	10	50	89%	6800
WRSD50-110S12	40-160V	12	4.17	100	90%	680
WRSD50-110S15	40-160V	15	3.33	100	90%	680
WRSD50-110S24	40-160V	24	2.08	100	89%	470
WRSD50-110S36	40-160V	36	1.39	200	89%	470
WRSD50-110S48	40-160V	48	1.04	480	88%	220
WRSD50-110S54	40-160V	54	0.92	480	89%	470

WRSD30-24S3V3	9V-36V	3.3	6	50	86%	6800
WRSD30-24S5	9V-36V	5.05	6	50	90%	6800
WRSD30-24S12	9V-36V	12	2.5	100	90%	680
WRSD30-24S15	9V-36V	15	2	100	90%	680
WRSD30-24S24	9V-36V	24	1.25	100	89%	470
WRSD50-24S3V3	9V-36V	3.3	10	50	86%	6800
WRSD50-24S5	9V-36V	5.05	10	50	90%	6800
WRSD50-24S12	9V-36V	12	4.17	100	91%	680
WRSD50-24S15	9V-36V	15	3.33	100	91%	680
WRSD50-24S24	9V-36V	24	2.08	100	89%	470
WRSD50-24S36	9V-36V	36	1.39	200	89%	470
WRSD50-24S48	9V-36V	48	1.04	480	88%	220
WRSD50-24S54	9V-36V	54	0.92	480	89%	470
WRSD30-24D5	9-36V	±5.05	±3.0	80	86%	2200
WRSD30-24D12	9-36V	±12.0	±1.25	120	88%	1000
WRSD30-24D15	9-36V	±15.0	±1.0	150	88%	680
WRSD30-110D5	40-160V	±5.05	±3.0	80	86%	2200
WRSD30-110D12	40-160V	±12.0	±1.25	120	88%	1000
WRSD30-110D15	40-160V	±15.0	±1.0	150	88%	680

■说明：仅列出典型型号，其它型号，请确定功率，输入电压及输出电压，致电我公司。

## 磁兼容应用（EMC）

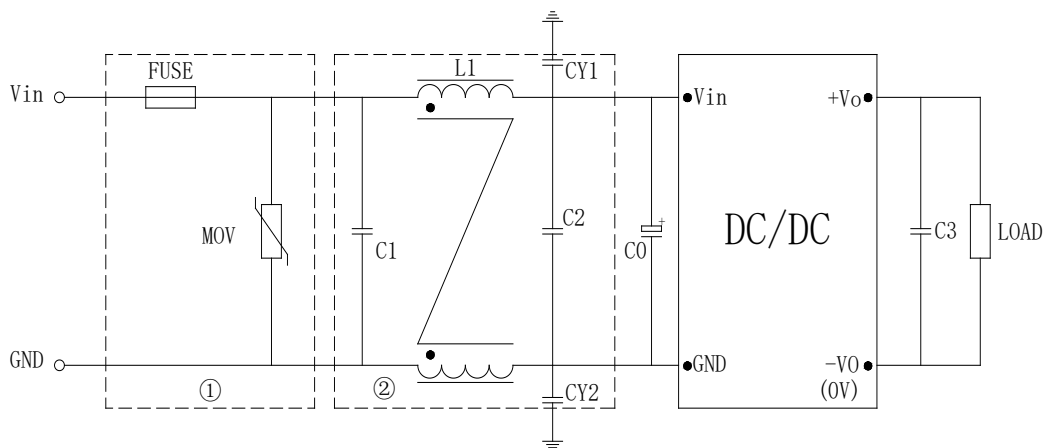

**FUSE:**推荐采用慢熔型的产品，FUSE 电流选择要考虑高温降额和冲击电流的影响。

**MOV:**压敏电阻，MOV 可以和保险丝串联应用，防止 MOV 失效。也可以两只 MOV 串联，增加可靠性。

**C0 C3:**高频电解电容

**C1 C2:**高频独石电容或者薄膜电容。

**LCM:**共模电感。具体型号请咨询销售人员。

**CY1 CY2:**安规 Y2 电容

型号	Vin: 110V
FUSE	6A 慢熔
MOV	14D201K
C0	100μF/250V
C1、C2	1μF/250V
C3	100μF
LCM	10mH
CY1、CY2	2.2nF Y2 安规电容

## 输出调节应用 (TRIM Function)

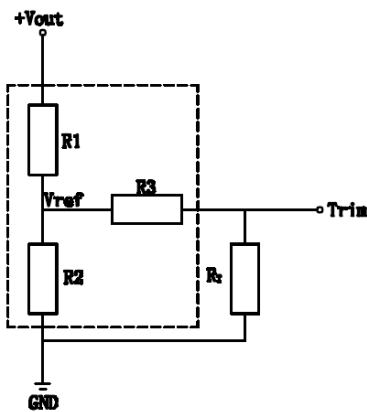

$$up : R_T = \frac{TR_2}{R_2 - T} - R_3$$

$$T = \frac{V_{ref}}{V_o' - V_{ref}} \cdot R_1$$

$$down : R_T = \frac{TR_1}{R_1 - T} - R_3$$

$$T = \frac{V_o' - V_{ref}}{V_{ref}} \cdot R_2$$

Trim up

Vout (V)	R1(KΩ)	R2(KΩ)	R3(KΩ)	Vref(V)
3.3	3.32	2.0	8.2	1.24
5	2.55	2.49	8.2	2.5
12	9.53	2.49	12	2.5
15	12.5	2.49	15	2.5
24	21.5	2.49	20	2.5
36	33.51	2.49	20	2.5
48	45.3	2.49	20	2.5
54	51.5	2.49	20	2.5

## 机械图及管脚说明 (Mechanical Chart、Pins) (Unit: mm/inch)

### 标准型

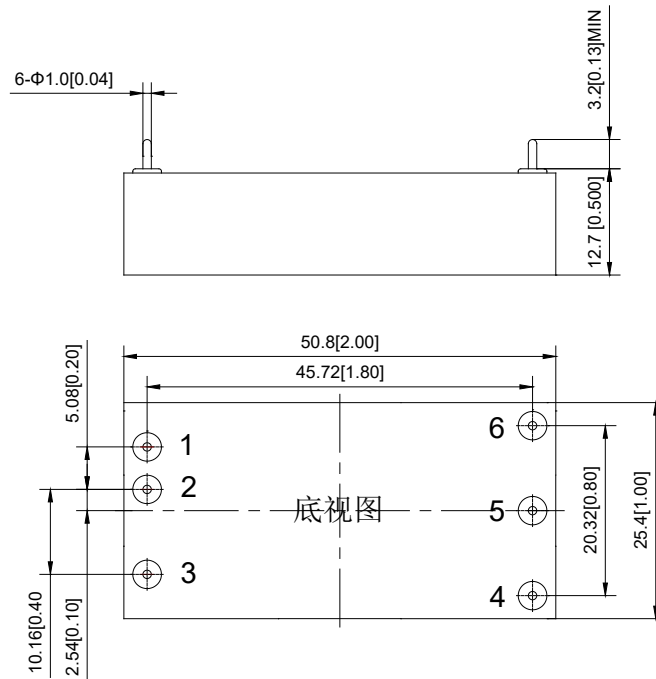

### 带散热器尾缀加 H

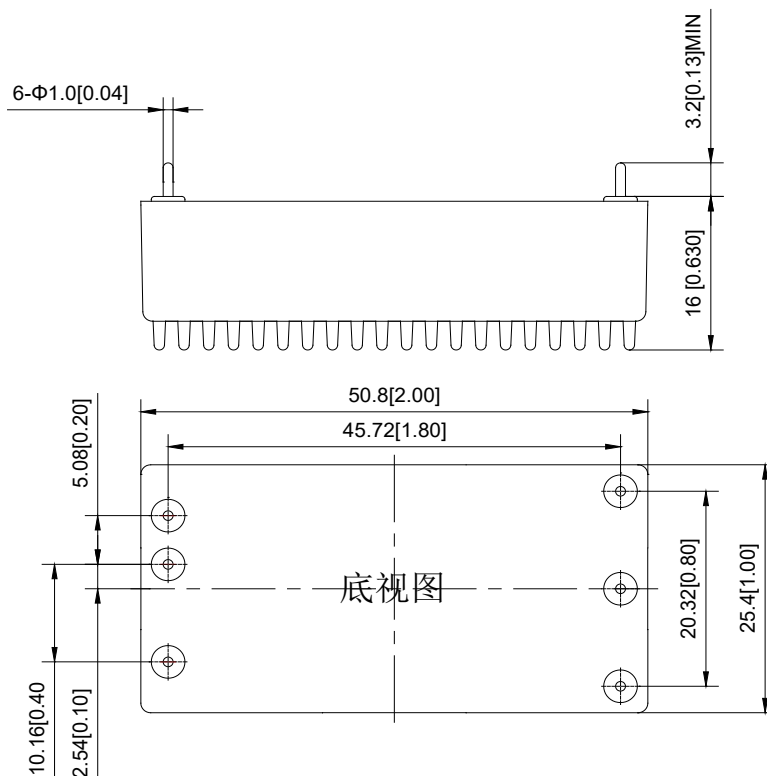

管脚	1	2	3	4	5	6
单路	+Vin	-Vin	CNT	TRIM	-Vo	+Vo
双路	+Vin	-Vin	CNT	-Vo	COM	+Vo

注：安装定位尺寸公差按 GB/T1804-2000 F 级标准、外型尺寸公差按 GB/T1804-2000 C 级标准。

尾缀为 D1 的机械图

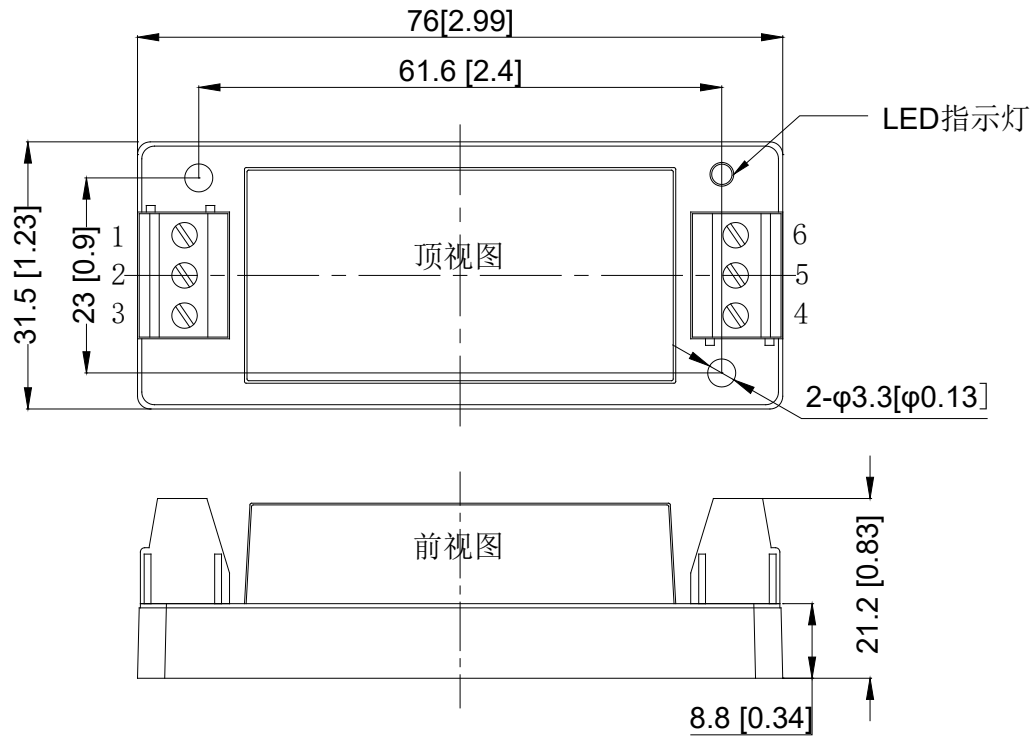

接线线径: 24-12AWG

紧固力矩: Max 0.4N.m

管脚 Pin	1	2	3	4	5	6
单路	CNT	-Vin	+Vin	+Vo	TRIM	-Vo
双路	CNT	-Vin	+Vin	+Vo	COM	-Vo

尾缀为 D2 的机械图

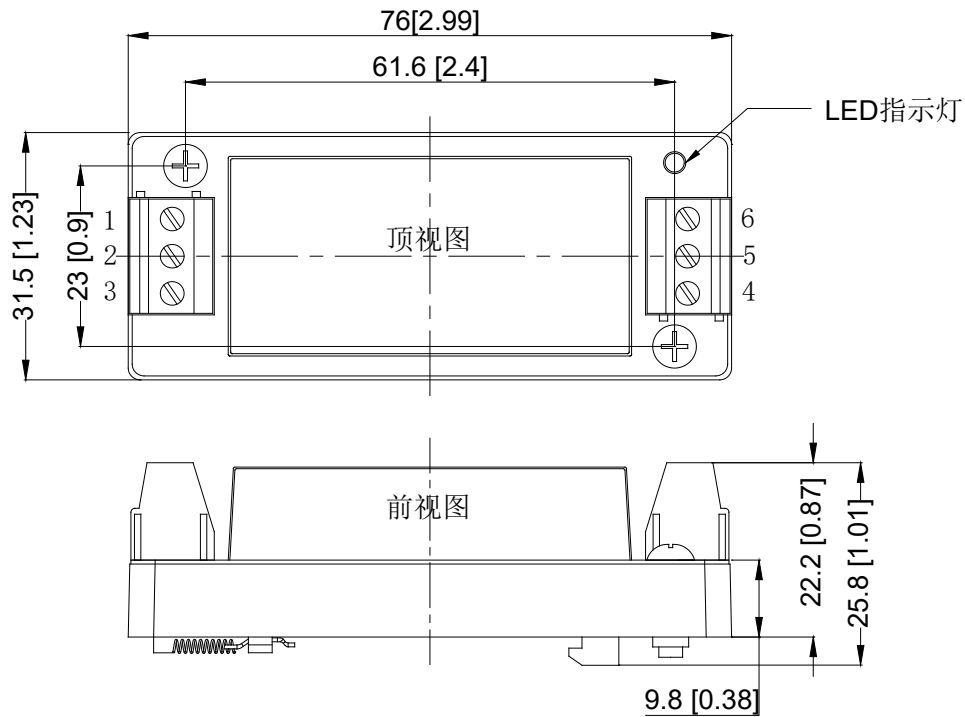

接线线径: 24-12AWG

紧固力矩: Max 0.4N.m

管脚	1	2	3	4	5	6
单路	CNT	-Vin	+Vin	+Vo	TRIM	-Vo
双路	CNT	-Vin	+Vin	+Vo	COM	-Vo

注:安装定位尺寸公差按 GB/T1804-2000 F 级标准、外型尺寸公差按 GB/T1804-2000 C 级标准。