

## 典型性能 Features

- ◆ 10-16 瓦功率输出 (10-16 Watts of Output Power)
- ◆ 超宽电压输入 (2: 1 Wide Range Input)
- ◆ 长期短路保护, 自恢复 (Short Circuit Protection ,Automatic Recovery)
- ◆ 小型化封装 (Small Package)



## 电气特性 Electrical Specifications

输入特性 Input	Min	Type	Max	Notes
输入电压范围 Input Voltage Range	4.5V	5V	9V	
	9V	12V	18V	W尾缀提供5-15V
	18V	24V	36V	W尾缀提供9-36V
	36V	48V	72V	W尾缀提供18-72V
	66V	74V/110V	160V	W尾缀提供40-160V
控制功能(限 C 尾缀) ON/OFF Control		ON		CNT 悬空或接TTL高电平 CNT pin left open or CNT pin connected to TTL logic high
		OFF		CNT 与-Vin 相连 CNT pin is at a logic low
逻辑低 Logic Low			1.2 V	
输入欠压保护(限 C 尾缀) Input. Under-voltage Lockout	15V		18V	24V 输入
	32V		36V	48V 输入
	55V		66V	110V 输入
启动延时时间 Start-up Delay Time		10mS		16W
		200mS		10W
输出特性 Output	Min	Type	Max	Notes
输出电压精度 Set point Accuracy			±1%	一路
			±3%	二路
负载效应 Load Regulation			±0.5%	一路
源效应 Line Regulation			±0.2%	一路
输出电压调节 TRIM Range			±10%	(限C尾缀)
动态响应 Dynamic Response			4% Vo Pk deviation 400µs settling time	50~75% load 50~25% load

温度系数 Temperature Regulation		±0.2%/°C			
输出过流保护 Current Limit Threshold	110%		160%		
输出过压保护 Over-voltage Protection	110%		140%	(限C尾缀)	
短路保护 Short-Circuit Protection	长期短路自恢复 Continuous, Automatic Recovery				
<b>综合特性 General</b>	<b>Min</b>	<b>Type</b>	<b>Max</b>	<b>Notes</b>	
隔离电压 Isolation Voltage	1500Vdc			INPUT TO OUT	
开关频率 Switching Frequency		300KHz			
平均故障间隔时间 MTBF		2×10 <sup>6</sup> Hrs		Mil HDBK 217F Tc=25°C	
工作壳温 Case Temperature	工业级	-40°C		+90°C	
	AD、AG 级	-40°C		+95°C	需散热器
	AHII 级	-55°C		+105°C	需散热器
储存温度 Storage Temperature		-55°C		+125°C	
相对湿度 Relative Humidity		10%		90%	
管脚焊接温度 Pin Solder Temperature				250°C	Wave Solder <10S
手工焊接时间 Hand Soldering Time				5S	Iron Temperature 425 °C
传导 Conducted Emission	GB9254/CISPR22/EN55022 Class B (推荐电路见图)				
静电放电 Electrostatic Discharge	GB17626/EN61000-4-2 Contact ±6KV air ±8KV perf. Criteria A				
浪涌抗扰度 Surge Immunity	GB17626/EN61000-4-5 ±2KV (推荐电路见图) perf. Criteria A				
脉冲群抗扰度 Electrical Fast Transient	GB17626/EN61000-4-4 ±2KV (推荐电路见图) perf. Criteria A				

型号 Models	输入电压范围 Input Voltage Range	输出电压 (Vdc) Output Voltage	输出电流 (A) Output current	纹波噪声(mv) Ripple and noise	典型效率 Efficiency	容性负载(μF) Max.Capacitor Load
WD10-12S3V3	9-18V	3.3	2.5	50	75%	1000
WD10-12S5	9-18V	5.05	2	50	80%	1000
WD10-12S12	9-18V	12	0.83	100	80%	470
WD10-12S15	9-18V	15	0.67	100	80%	470

WD10-12S24	9-18V	24	0.42	100	82%	220
WD10-12S48	9-18V	48	0.21	200	80%	100
WD10-24S3V3	18-36V	3.3	2.5	50	76%	1000
WD10-24S5	18-36V	5.05	2	50	80%	1000
WD10-24S12	18-36V	12	0.83	100	82%	470
WD10-24S15	18-36V	15	0.67	100	83%	470
WD10-24S24	18-36V	24	0.42	100	84%	220
WD10-24S48	18-36V	48	0.21	200	83%	100
WD10-48S3V3	36-72V	3.3	2.5	50	78%	1000
WD10-48S5	36-72V	5.05	2	50	82%	1000
WD10-48S12	36-72V	12	0.83	100	83%	470
WD10-48S15	36-72V	15	0.67	100	84%	470
WD10-48S24	36-72V	24	0.42	100	84%	220
WD10-48S48	36-72V	48	0.21	200	84%	100
WD10-110S3V3	66-160V	3.3	2.5	50	76%	1000
WD10-110S5	66-160V	5.05	2	50	81%	1000
WD10-110S12	66-160V	12	0.83	100	83%	470
WD10-110S15	66-160V	15	0.67	100	84%	470
WD10-110S24	66-160V	24	0.42	100	84%	220
WD10-110S48	66-160V	48	0.21	200	82%	100
WD12-12S3V3	9-18V	3.3	3	50	76%	1000
WD12-12S5	9-18V	5.05	2.4	50	80%	1000
WD12-12S12	9-18V	12	1	100	81%	470
WD12-12S15	9-18V	15	0.8	100	81%	470
WD12-12S24	9-18V	24	0.5	100	82%	220
WD12-12S48	9-18V	48	0.25	200	80%	100
WD12-24S3V3	18-36V	3.3	3	50	77%	1000
WD12-24S5	18-36V	5.05	2.4	50	81%	1000
WD12-24S12	18-36V	12	1	100	83%	470
WD12-24S15	18-36V	15	0.8	100	83%	470

WD12-24S24	18-36V	24	0.5	100	84%	220
WD12-24S48	18-36V	48	0.25	200	80%	100
WD12-48S3V3	36-72V	3.3	3	50	79%	1000
WD12-48S5	36-72V	5.05	2.4	50	82%	1000
WD12-48S12	36-72V	12	1	100	83%	470
WD12-48S15	36-72V	15	0.8	100	83%	470
WD12-48S24	36-72V	24	0.5	100	84%	220
WD12-48S48	36-72V	48	0.25	200	81%	100
WD12-110S3V3	66-160V	3.3	3	50	78%	1000
WD12-110S5	66-160V	5.05	2.4	50	80%	1000
WD12-110S12	66-160V	12	1	100	83%	470
WD12-110S15	66-160V	15	0.8	100	83%	470
WD12-110S24	66-160V	24	0.5	100	83%	220
WD12-110S48	66-160V	48	0.25	200	80%	100
WD16-12S5	9-18V	5.05	3	50	82%	1000
WD16-12S12	9-18V	12	1.25	100	85%	470
WD16-12S15	9-18V	15	1	100	85%	470
WD16-12S24	9-18V	24	0.63	100	85%	220
WD16-12S48	9-18V	48	0.31	200	80%	100
WD16-24S5	18-36V	5.05	3	50	82%	1000
WD16-24S12	18-36V	12	1.25	100	85%	470
WD16-24S15	18-36V	15	1	100	85%	470
WD16-24S24	18-36V	24	0.63	100	86%	220
WD16-24S48	18-36V	48	0.31	200	81%	100
WD16-48S5	36-72V	5.05	3	50	84%	1000
WD16-48S12	36-72V	12	1.25	100	85%	470
WD16-48S15	36-72V	15	1	100	85%	470
WD16-48S24	36-72V	24	0.63	100	86%	220
WD16-48S48	36-72V	48	0.31	200	81%	100
WD16-110S5	66-160V	5.05	3	50	83%	1000

WD16-110S12	66-160V	12	1.25	100	85%	470
WD16-110S15	66-160V	15	1	100	85%	470
WD16-110S24	66-160V	24	0.63	100	86%	220
WD16-110S48	66-160V	48	0.31	200	80%	100
WD10-12D5	9-18V	+5.05/-5.05	+1/-1	50/50	79%	470/470
WD10-12D12	9-18V	+12/-12	+0.42/-0.42	100/100	80%	220/220
WD10-12D15	9-18V	+15/-15	+0.33/-0.33	100/100	80%	220/220
WD10-24D5	18-36V	+5.05/-5.05	+1/-1	50/50	80%	470/470
WD10-24D12	18-36V	+12/-12	+0.42/-0.42	100/100	82%	220/220
WD10-24D15	18-36V	+15/-15	+0.33/-0.33	100/100	82%	220/220
WD10-48D5	36-72V	+5.05/-5.05	+1/-1	50/50	81%	470/470
WD10-48D12	36-72V	+12/-12	+0.42/-0.42	100/100	82%	220/220
WD10-48D15	36-72V	+15/-15	+0.33/-0.33	100/100	82%	220/220
WD10-110D5	66-160V	+5.05/-5.05	+1/-1	50/50	82%	470/470
WD10-110D12	66-160V	+12/-12	+0.42/-0.42	100/100	83%	220/220
WD10-110D15	66-160V	+15/-15	+0.33/-0.33	100/100	83%	220/220
WD12-12D5	9-18V	+5.05/-5.05	+1.2/-1.2	50/50	79%	470/470
WD12-12D12	9-18V	+12/-12	+0.5/-0.5	100/100	80%	220/220
WD12-12D15	9-18V	+15/-15	+0.4/-0.4	100/100	80%	220/220
WD12-24D5	18-36V	+5.05/-5.05	+1.2/-1.2	50/50	80%	470/470
WD12-24D12	18-36V	+12/-12	+0.5/-0.5	100/100	82%	220/220
WD12-24D15	18-36V	+15/-15	+0.4/-0.4	100/100	82%	220/220
WD12-48D5	36-72V	+5.05/-5.05	+1.2/-1.2	50/50	82%	470/470
WD12-48D12	36-72V	+12/-12	+0.5/-0.5	100/100	83%	220/220
WD12-48D15	36-72V	+15/-15	+0.4/-0.4	100/100	83%	220/220
WD12-110D5	66-160V	+5.05/-5.05	+1.2/-1.2	50/50	83%	470/470
WD12-110D12	66-160V	+12/-12	+0.5/-0.5	100/100	84%	220/220
WD12-110D15	66-160V	+15/-15	+0.4/-0.4	100/100	84%	220/220
WD16-12D5	9-18V	+5.05/-5.05	+1.5/-1.5	50/50	84%	470/470
WD16-12D12	9-18V	+12/-12	+0.63/-0.63	100/100	85%	220/220

WD16-12D15	9-18V	+15/-15	+0.5/-0.5	100/100	86%	220/220
WD16-24D5	18-36V	+5.05/-5.05	+1.5/-1.5	50/50	84%	470/470
WD16-24D12	18-36V	+12/-12	+0.63/-0.63	100/100	85%	220/220
WD16-24D15	18-36V	+15/-15	+0.5/-0.5	100/100	86%	220/220
WD16-48D5	36-72V	+5.05/-5.05	+1.5/-1.5	50/50	84%	470/470
WD16-48D12	36-72V	+12/-12	+0.63/-0.63	100/100	85%	220/220
WD16-48D15	36-72V	+15/-15	+0.5/-0.5	100/100	86%	220/220
WD16-110D5	66-160V	+5.05/-5.05	+1.5/-1.5	50/50	84%	470/470
WD16-110D12	66-160V	+12/-12	+0.63/-0.63	100/100	85%	220/220
WD16-110D15	66-160V	+15/-15	+0.5/-0.5	100/100	86%	220/220

■说明：仅列出典型型号，其它型号，请确定功率，输入电压及输出电压，致电我公司。

## 电磁兼容应用（EMC）

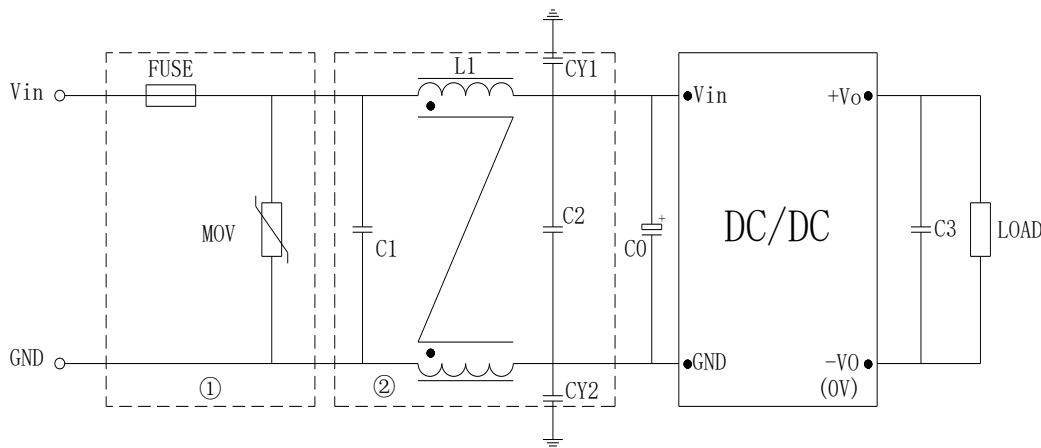

型号	Vin: 24V	Vin: 48V	110V
FUSE	4A 慢熔	2A 慢熔	2A 慢熔
MOV	14D101K	14D101K	14D201K
C0	220μF/50V	100μF/100V	68μF/250V
C1、C2	4.7μF/50V	2.2μF/100V	1μF/250V
C3	100μF		
LCM	1mH		
CY1、CY2	2.2nF Y2 安规电容		

**FUSE:**推荐采用慢熔型的产品，FUSE 电流选择要考虑高温降额和冲击电流的影响。

**MOV:**压敏电阻，MOV 可以和保险丝串联应用，防止 MOV 失效。也可以两只 MOV 串联，增加可靠性。

**C0 C3:**高频电解电容

**C1 C2:**高频独石电容或者薄膜电容。

**LCM:**共模电感。具体型号请咨询销售人员。

CY1 CY2:安规 Y2 电容

输出调节应用 (TRIM Function)

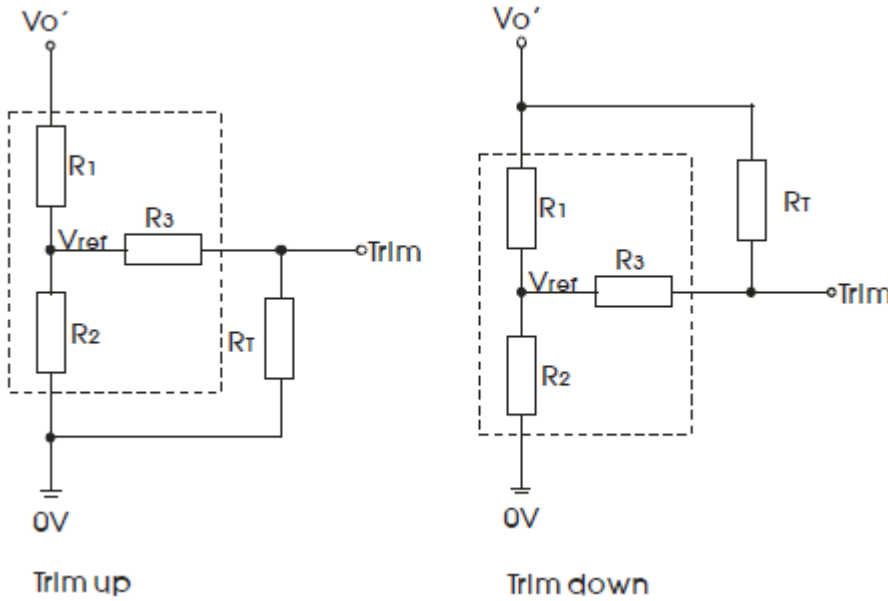

$$up: R_T = \frac{TR_2}{R_2 - T} - R_3 \quad T = \frac{V_{ref}}{V_{o'} - V_{ref}} \cdot R_1 \text{ (调高电压)}$$

$$down: R_T = \frac{TR_1}{R_1 - T} - R_3 \quad T = \frac{V_{o'} - V_{ref}}{V_{ref}} \cdot R_2 \text{ (调低电压)}$$

Vout (V)	R1(KΩ)	R2(KΩ)	R3(KΩ)	Vref(V)
3.3	3.32	2.0	8.2	1.24
5	2.55	2.49	8.2	2.5
9	6.49	2.49	10	2.5
12	9.53	2.49	12	2.5
15	12.5	2.49	15	2.5
24	21.5	2.49	20	2.5
48	45.3	2.49	20	2.5

遥控应用 (CNT Function)

CNT 控制既可通过开关实现也可通过与 CNT 端子串联的晶体管实现。在有些应用中可能要用到隔离控制的方式隔离控制可通过光耦或继电器进行 当控制线很长时可能在 CNT 端引入一些干扰建议在 CNT 端和 -Vin 之间并接一个 0.1uF 电容。

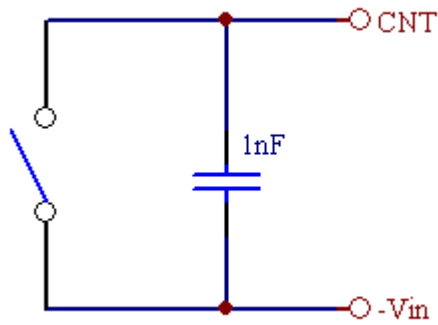

机械图及管脚说明 (Mechanical Chart、Pins) (Unit: mm/ inch)

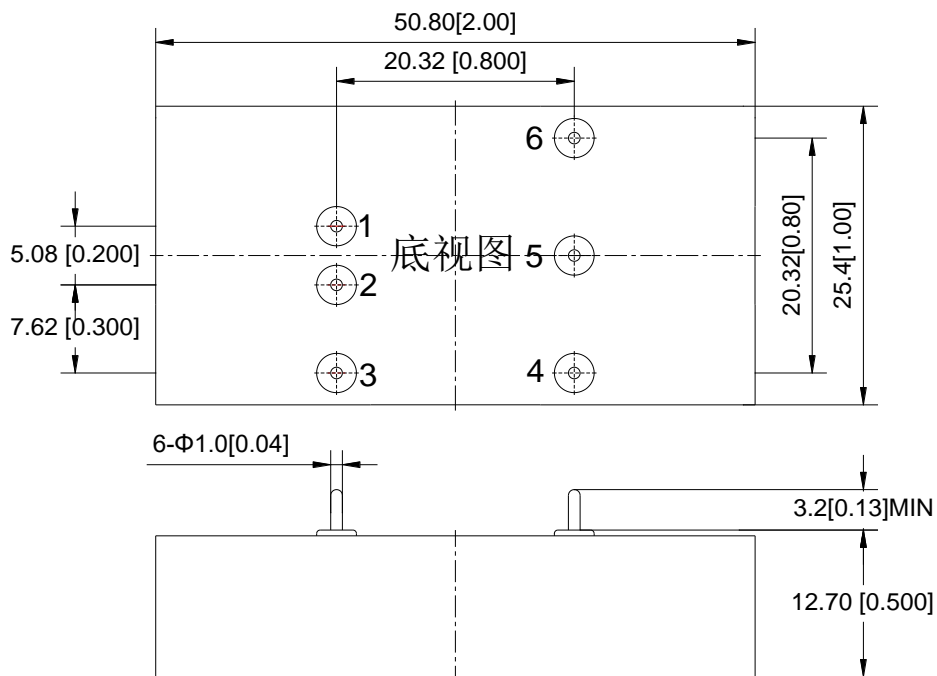

管脚 Pin	1	2	3	4	5	6
单路 Single	+Vin	-Vin	NP	-Vo	NP	+Vo
双路 Dual	+Vin	-Vin	NP	-Vo2	COM	+Vo1
单路 C 尾缀	+Vin	-Vin	CNT	-Vo	TRIM	+Vo
双路 C 尾缀	+Vin	-Vin	CNT	-Vo2	COM	+Vo1

注:安装定位尺寸公差按 GB/T1804-2000 F 级标准、外型尺寸公差按 GB/T1804-2000 C 级标准。