

典型性能 Features

- ◆ 75~150 瓦功率输出 (75~150 Watts of Output Power)
- ◆ 宽电压输入 (Wide Range Input)
- ◆ 长期短路保护, 自恢复 (Short Circuit Protection, Automatic Recovery)
- ◆ 小型化封装 (Small Package)

电气特性 Electrical Specifications

输入特性 Input	Min	Type	Max	Notes
输入电压范围 Input Voltage Range	165Vac	220Vac	265Vac	
	85Vac	220Vac	265Vac	输入电压宽范围, 尾缀加W
输入频率 Input Frequency	45Hz	50/60Hz	65Hz	
输出特性 Output	Min	Type	Max	Notes
输出电压精度 Set point Accuracy			±1%	Vo
源效应 Line Regulation			±0.2%	Vo
负载效应 Load Regulation			±0.5%	Vo
输出电压调节 TRIM Range			±10%	Vo
纹波噪声 (注 1) Ripple and Noise			80mV 100mV 200mV	Vo≤5V Other Vo≥36V
动态响应 Dynamic Response		±4% Vo Pk deviation 400μs settling time		50~75% Load 50~25% Load
温度系数 Temperature Regulation		±0.2%/°C		
短路保护 Short-Circuit Protection	长期短路自恢复 Continuous, Automatic Recovery			
综合特性 General	Min	Type	Max	Notes
隔离电压 Isolation Voltage			1500Vac	输入与输出 Input-Output
			1500Vac	输入与壳 Input-Case
			500Vac	输出与壳 Output-Case
开关频率 Switching Frequency	50KHz		150KHz	
平均故障间隔时间 MTBF		3×10 ⁵ Hrs		Mil HDBK 217F Tc=25°C
工作壳温 (注 3) Case Temperature	工业级	-25°C		+85°C
	AD 级	-40°C		+90°C
	AG、AH	-40°C		+90°C
	AHII	-55°C		+90°C

储存温度 Storage Temperature	-45℃		+105℃	
相对湿度 Relative Humidity	10%		90%	
管脚焊接温度 Pin Solder Temperature			250℃	Wave Solder <10S
手工焊接时间 Hand Soldering Time			5S	Iron Temperature 425 °C
传导（注4） Conducted Emission	GB9254/CISPR22/EN55022 Class B（推荐电路见图）			
静电放电 Electrostatic Discharge	GB17626/EN61000-4-2 Contact ±4KV			
浪涌抗扰度 Surge Immunity	GB17626/EN61000-4-5 ±2KV（推荐电路见图） perf. Criteria B			
脉冲群抗扰度 Electrical Fast Transient	GB17626/EN61000-4-4 ±2KV（推荐电路见图） perf. Criteria B			

注 1：纹波噪声采用 20MHz 带宽、平行线法测试；

注 2：交流电压测试漏电流为 5mA，直流电压测试漏电流为 0.5mA；

注 3：若符合相关行业 EMI 标准，需增加外围推荐电路或者滤波器；

产品型号列表 Product Model List

型号 Models	输入电压 范围 Input Voltage Range	输出电压 (Vdc) Output Voltage	输出电流 (A) Output Current	纹波噪声 (mv) Ripple and noise	典型效率 Efficiency	容性负载 (μF) Max.Capacitor Load
WAN75S5	165-265Vac	5.05	15	80	81%	10000
WAN75S9	165-265Vac	9	8.33	100	82%	2200
WAN75S12	165-265Vac	12	6.25	100	83%	2200
WAN75S15	165-265Vac	15	5	100	83%	2200
WAN75S18	165-265Vac	18	4.17	100	84%	1000
WAN75S24	165-265Vac	24	3.13	100	85%	1000
WAN75S28	165-265Vac	28	2.68	100	85%	1000
WAN75S36	165-265Vac	36	2.08	200	86%	470
WAN75S48	165-265Vac	48	1.56	200	87%	470
WAW75S12	85-265Vac	12	6.25	100	82%	2200
WAW75S15	85-265Vac	15	5	100	82%	2200
WAW75S18	85-265Vac	18	4.17	100	83%	1000
WAW75S24	85-265Vac	24	3.13	100	84%	1000
WAW75S28	85-265Vac	28	2.68	100	84%	1000
WAW75S36	85-265Vac	36	2.08	200	85%	470
WAW75S48	85-265Vac	48	1.56	200	86%	470
WAN100S9	165-265Vac	9	11.1	100	82%	2200
WAN100S12	165-265Vac	12	8.33	100	83%	2200
WAN100S15	165-265Vac	15	6.67	100	83%	2200
WAN100S18	165-265Vac	18	5.56	100	84%	1000
WAN100S24	165-265Vac	24	4.17	100	85%	1000
WAN100S28	165-265Vac	28	3.57	100	85%	1000
WAN100S36	165-265Vac	36	2.78	200	86%	470
WAN100S48	165-265Vac	48	2.08	200	87%	470
WAN150S12	165-265Vac	12	12.5	100	83%	2200
WAN150S15	165-265Vac	15	10	100	83%	2200
WAN150S18	165-265Vac	18	8.33	100	84%	1000

WAN150S24	165-265Vac	24	6.25	100	85%	1000
WAN150S28	165-265Vac	28	5.36	100	85%	1000
WAN150S36	165-265Vac	36	4.17	200	86%	470
WAN150S48	165-265Vac	48	3.13	200	87%	470

注 5: 我公司该系列产品按照输出电压大小进行分类; 可参考“机械图及管脚说明”来确定外壳、管脚定义和产品名称; 以上表格中仅列出典型型号, 我公司可根据客户需求信息 (包括功率、输入电压、输出电压、负载特性等) 来单独设计。

电磁兼容应用 (EMC)

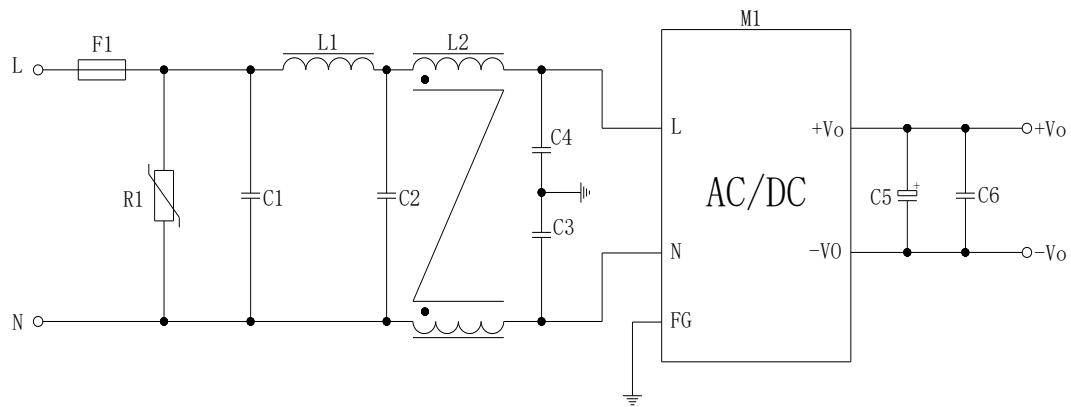

型号	输出电压 5V	输出电压 9V/12V/15V	输出电压 18V/24V
F1 (保险丝)	5~10A 慢熔		
R1 (压敏电阻)	471KD14		
C1/C2 (X 电容)	0.47μF/275Vac		
C3/C4 (Y 电容)	2.2nF/250Vac		
L1 (差模电感)	100~300μH		
L2 (共模电感)	10mH		
C5 (电解电容)	470μF/16V	470μF/25V	220μF/35V
C6 (陶瓷电容)	1μF/50V		

输出调节应用 (TRIM Function)

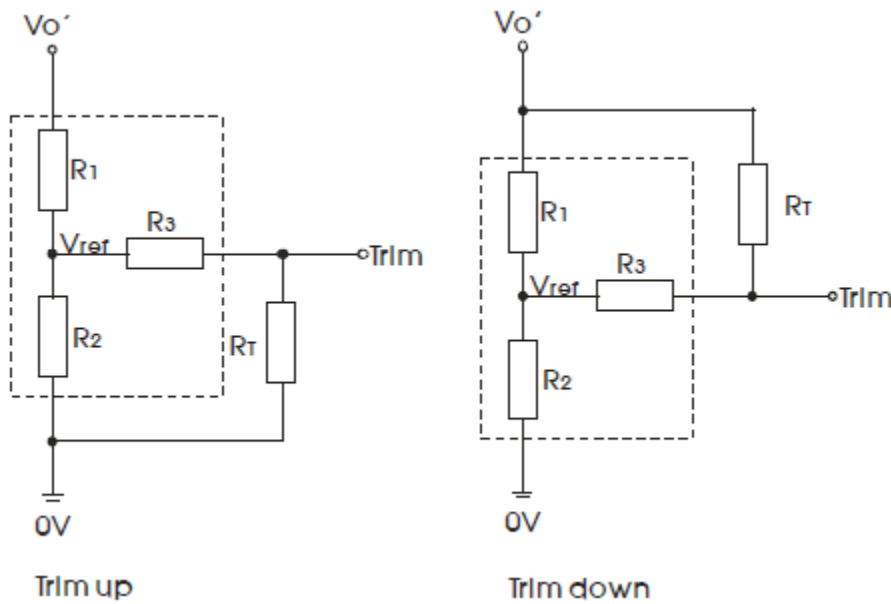

$$up: R_T = \frac{TR_2}{R_2 - T} - R_3 \quad T = \frac{V_{ref}}{V_{o'} - V_{ref}} \cdot R_1$$

$$down: R_T = \frac{TR_1}{R_1 - T} - R_3 \quad T = \frac{V_{o'} - V_{ref}}{V_{ref}} \cdot R_2$$

Vout (V)	R1 (KΩ)	R2 (KΩ)	R3 (KΩ)	Vref (V)
3.3	3.32	2.0	8.2	1.24
5	2.55	2.49	8.2	2.5
12	9.53	2.49	12	2.5
15	12.5	2.49	15	2.5
24	21.5	2.49	20	2.5

机械图及管脚说明 (Mechanical Chart、Pins) (Unit: mm/inch)

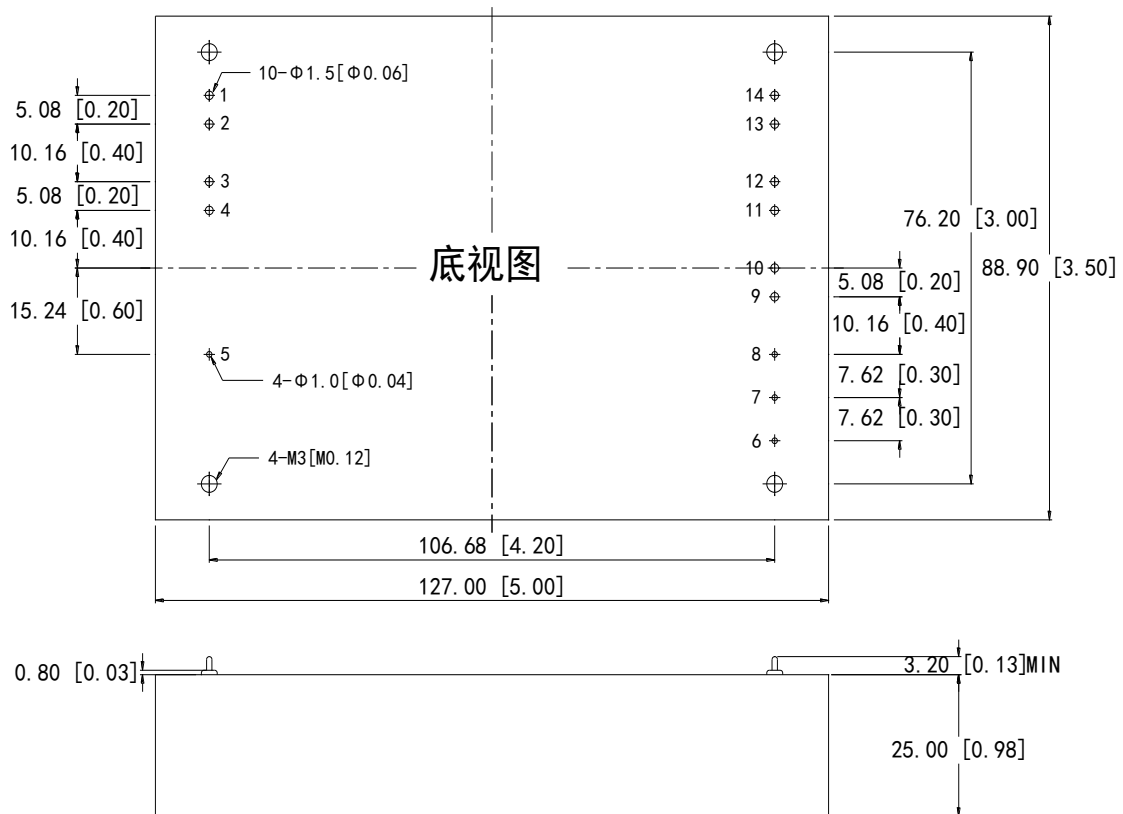

标准型

项目	输入端			输出端					
	1/2	3/4	5	6	7	8	9/10	11/12	13/14
管脚	1/2	3/4	5	6	7	8	9/10	11/12	13/14
定义	L	N	FG	-S	Trim	+S	NC	-Vo	+Vo
说明	火线	零线	地线	负远传	输出电压可调	正远传	无连接空管脚	输出负	输出正

注 6: 安装定位尺寸公差按 GB/T1804-2000 F 级标准, 外型尺寸公差按 GB/T1804-2000 C 级标准;

注 7:

- 1) 管脚顺序依次从左往右;
- 2) 输出针中第 1~4 和 11~14 管脚直径为 2.0mm, 建议 PCB 安装孔直径为 2.6~3.0mm; 输出针第 5~10 管脚直径为 1.0mm, 建议 PCB 安装孔直径为 1.4~1.8mm

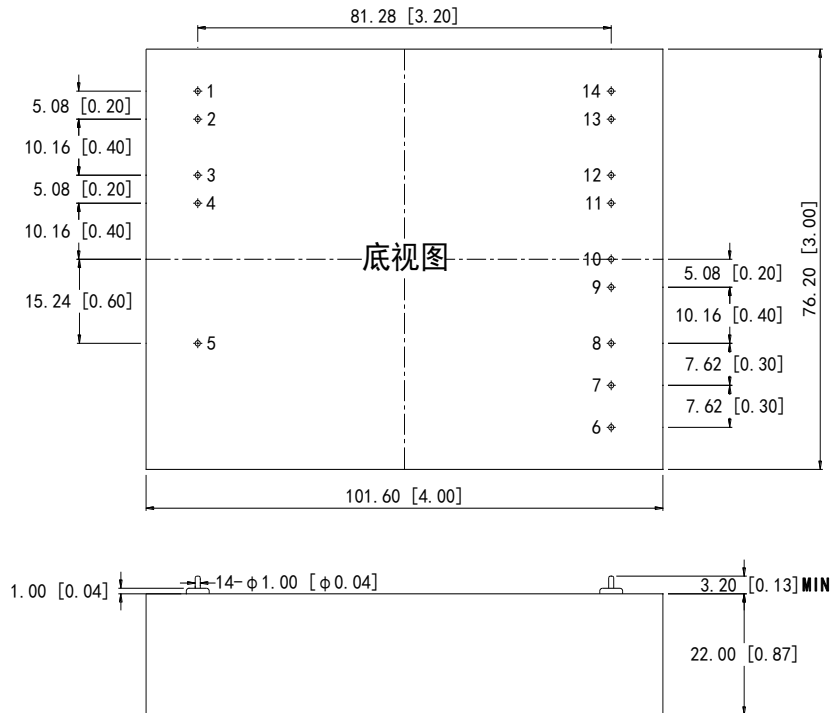

MINI 型

1) 单路输出电源管脚定义，产品尾缀加 M（如 WAN75S12M）：

项目	输入端			输出端					
	1/2	3/4	5	6	7	8	9/10	11/12	13/14
管脚	L	N	FG	-S	Trim	+S	NC	-Vo	+Vo
定义	L	N	FG	-S	Trim	+S	NC	-Vo	+Vo
说明	火线	零线	地线	负远传	输出电压可调	正远传	无连接空管脚	输出负	输出正